

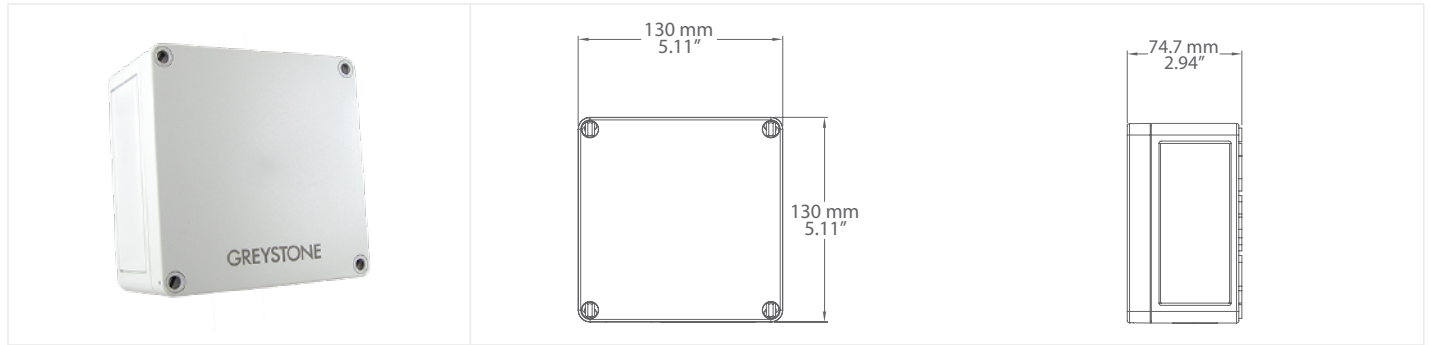

OUTSIDE PARTICULATE MATTER SENSOR



PMOS SERIES

PRODUCT DESCRIPTION

The PMOS Outside Particulate Matter Sensor uses an optical sensor based on laser scattering principles and features innovative contamination resistance technology to perform highly accurate and reliable PM measurements. The replaceable sensor measures particles of PM1.0, PM2.5, PM4.0, or PM10, with a continuous operation lifetime of more than 8 years. The sensor will provide long-term reliability and high resolution particle size binning for the detection of environmental dust and other particles.

TYPICAL INSTALLATION

For complete installation and wiring details, please refer to the product installation instructions.

The PMOS series should be mounted on an outside North facing wall, under the eaves which will provide protection from direct sunlight and wind.

The PMOS can be mounted directly to buildings wall face using the provided mounting holes. There are 0.85" knockouts for conduit connection.

The basic PMOS has a screw block terminal provided for connection to the Building Automation System.

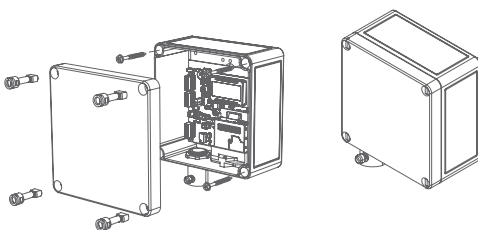

SPECIFICATIONS

SENSOR	Laser scatter method (field replaceable)
PARTICULATE SIZE	PM1.0, PM2.5, PM4.0, or PM10 (selectable)
MASS CONCENTRATION RANGE	0 - 1000 ug/m ³
RESOLUTION	1 ug/m ³
ACCURACY	±10 ug/m ³ (0 - 100 ug/m ³), ±10% (100 - 1000 ug/m ³)
RESPONSE TIME	1 second
SENSOR LIFETIME	>8 years
ANALOG MODEL	Consumption: 75 mA max @ 24 Vdc, 100 mA max @ 24 Vac Output Signals: 4-20 mA (sourcing) or 0-5 Vdc / 0-10 Vdc (selectable) Output Drive Capability: Current - 550Ω max Voltage - 5,000Ω min Output Scale: 0 to 1000 ug/m ³ (menu selectable)
BACnet® MODEL	Consumption: 50 mA max @ 24 Vdc, 80 mA max @ 24 Vac Interface: MS/TP, 2 wire RS-485 Baud Rate: 9600, 19200, 38400, 57600, 76800 or 115200 (menu selectable) Address Range: 0 - 127 (menu selectable)
MODBUS MODEL	Consumption: 50 mA max @ 24 Vdc, 80 mA max @ 24 Vac Interface: MS/TP, 2 wire RS-485, RTU Baud Rate: 9600, 19200, 38400, 57600, 76800 or 115200 (menu selectable) Address Range: 1-255 (menu selectable)
PM ALARM RELAY (OPTIONAL)	Contact Ratings: Form C (NO + NC), 2A @ 140 Vac, 2A @ 30 Vac Setpoint + Hysteresis: Programmable via menu
DISPLAY	Internal LCD for setup Display values Mass Concentration: 0 - 1000 ug/m ³ Air Quality Index: 0 - 500 AQI Good/Moderate/Poor (menu selectable)
POWER SUPPLY	24 Vac/dc ±20% (non-isolated half-wave rectified)
PROTECTION CIRCUITRY	Reverse voltage protected, over-voltage protected
OPERATING CONDITIONS	-10 to 60°C (14 to 140°F), 20 to 80 %RH non-condensing
STORAGE CONDITIONS	-30 to 60°C (-22 to 140°F)
ENCLOSURE	Polycarbonate, IP65 (NEMA 4X)
ENCLOSURE DIMENSIONS	130mm W x 130mm H x 75mm D (5.12" x 5.12" x 2.95")
WIRING	Screw terminal block (14 to 22 AWG)
COUNTRY OF ORIGIN	Canada



MCERTS CERTIFICATION

The PMRMC series incorporates the SPS30 PM sensor for accurate and reliable PM sensing. The SPS30 particulate matter sensor has achieved MCERTS certification, which proves the performance of the PM sensor. In addition, the certification confirms that the SPS30 can be easily integrated into applications that comply with the European Air Quality Standard DIN EN 15267.

The MCERTS certification scheme was established by the UK's Environment Agency and is built around international and European standards to ensure high-quality environmental data monitoring. The SPS30 underwent laboratory and field tests and has been proven to fulfill the latest MCERTS and associated DIN EN 15267 European air quality standards. Compliance with the above-mentioned standards requires low intra-model variability ($\leq 5 \mu\text{g}/\text{m}^3$), making the SPS30 the first choice for integration into applications requiring high precision. The certification is issued by the Sira Certification Service, one of the leading notified bodies in Europe. They are also accredited according to ISO/IEC 17065 UKAS and are part of the Canadian Standards Association (CSA Group).

Learn more about the MCERTS certification on the website of CSA Group or have a look at the certificate as linked below.

Website: <https://www.csagroupuk.org/services/mcerts/mcerts-product-certification/mcerts-certified-products/mcerts-certified-products-indicative-ambient-particulate-monitors/>

Certificate: https://www.sensirion.com/fileadmin/user_upload/customers/sensirion/Dokumente/9.6_Part particulate_Matter/Datasheets/Sensirion_PM_Sensors_SPS30_MCERTS-Certificate_2020.pdf

WIRING INFORMATION

TERMINAL	FUNCTION
PWR	+ 24 Vdc/24 Vac (HOT)
COM	Common
OUT	Analog Output
NO	Relay Normally Open Contact
R. COM	Relay Common
NC	Relay Normally Closed Contact
If BACnet® or Modbus Output Selected	
B(+)	Network Output
A(-)	Network Output
SHLD	Network Output

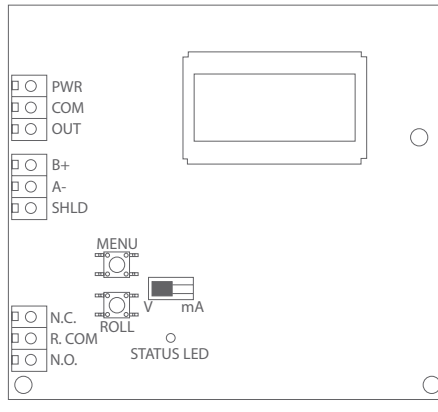

ORDERING

PRODUCT	PMOS	Outside Particulate Matter Sensor
RELAY	X R	None Alarm Relay
COMMUNICATIONS	X B M	Analog Output BACnet® Output Modbus Output

PART NUMBER

PMOS

NOTE: Greystone Energy Systems, Inc. reserves the right to make design modifications without prior notice.