

WIRELESS ROOM TRANSMITTER

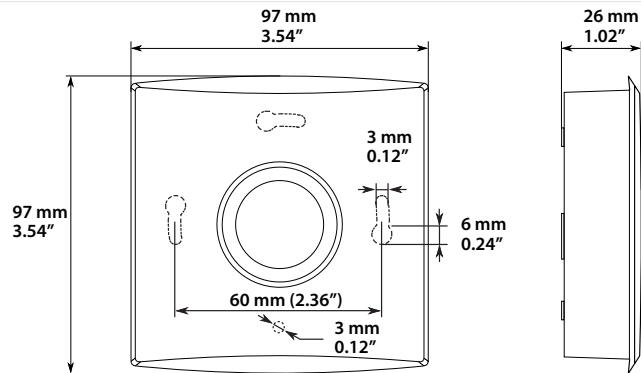

GWTR-IM SERIES

DIMENSIONS



PRODUCT DESCRIPTION

The GWTR-IM wireless input module reads values from three inputs. The input module includes also temperature and humidity measurements. The module can be powered with battery or with wired supply voltage and it is compatible with the Greystone MESH wireless network. The information is transmitted to the base unit according to the base unit poll interval or when the information changes. You can set the smallest change in the value that is send to the base unit. The wireless network needs one base unit. Commissioning is done by using the Greystone ConfigTool smart phone application.

NTC 10 INPUT ACCURACY

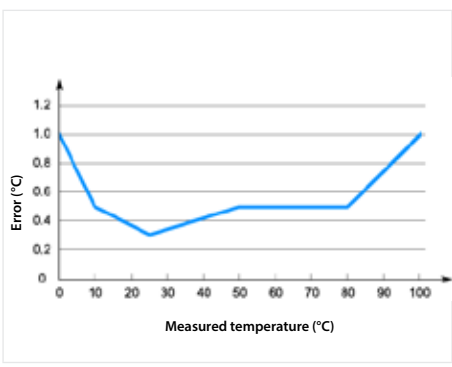

SPECIFICATIONS

Power Supply	3.6 V lithium battery (3600 mAh) or 10 to 30 Vdc / 12 to 28 Vac
Network frequency	2.4 GHz (2400...2483.5 MHz)
Maximum transmit power (E.I.R.P)	4 mW (6 dBm)
Bandwidth	2000 kHz
Modulation	GFSK
Network range (max distance between devices)	Up to 100 m (325 ft) in the line of sight, typically 10 to 20m (30 to 65 ft) inside buildings. Note: The maximum distance between devices depends on the installation environment.
TEMPERATURE MEASUREMENT (INTERNAL)	
Range	0 to 50 °C (32 to 122 °F)
Accuracy	Typically ±0.2 °C (±0.36 °F), max ±0.4 °C (±0.72 °F)
HUMIDITY MEASUREMENT (INTERNAL)	
Range	0 to 100 %rH
Accuracy	Typ. ±2 % RH (10 to 90 % RH), max. ±5 % RH
INPUTS	
Inputs	3 x 0 to 10 V / NTC 10K Type 2 / digital / resistive
0...10 V	< 2 mA
NTC 10	0 to 100 °C. See the temperature input accuracy from the NTC 10 input accuracy chart below
Digital	Potential free contact
Resistive	0 to 300000 Ω
Commissioning tool	Greystone ConfigTool App 
OPERATING CONDITIONS	
Appliance class (IEC 60664-1)	III
Operating Temperature	0 to 50 °C (32 to 122 °F)
Operating Humidity	0 to 85 % RH (non-condensing)
Housing Material	PC plastic, IP20
Protection Class	IP30
Mounting	On the wall surface or on the standard flush mounting box (60 mm holespacing)
Dimensions (w x h x d)	97 x 97 x 33 mm (3.82" x 3.82" x 1.30")
Approvals	CE, UKCA, FCC, ISED

WIRING INFORMATION

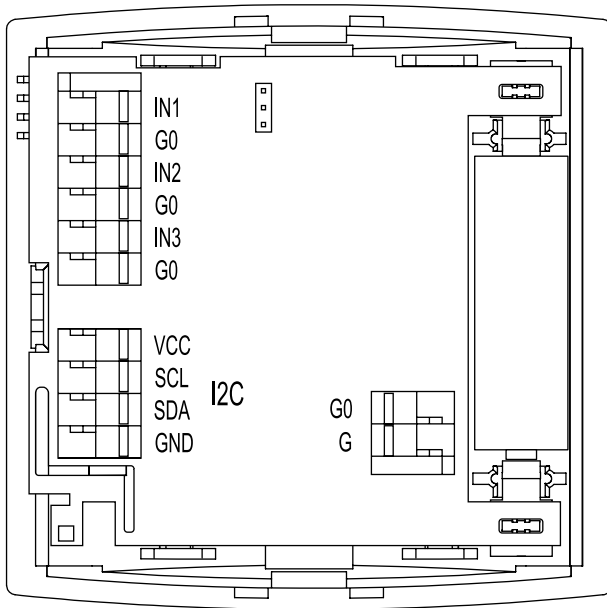

TERMINAL

IN1
G0

FUNCTION

Input 1 (0 to 10 V or NTC 10 or digital or resistive)

IN2
G0

Input 2 (0 to 10 V or NTC 10 or digital or resistive)

IN3
G0

Input 3 (0 to 10 V or NTC 10 or digital or resistive). The input supports energy harvesting from 0...10 V signal when the device is battery powered. The harvesting is active if the signal is over 4 V.

Note: When using 0...10 V inputs, the input potential must be the same that is used in the connected 0...10 V device. Use common G0 with the connected device's power supply, for example.

Note: Use NO type contact for digital input, if the device is only battery powered. NC requires power and that significantly shortens the battery life.

I2C MODELS

VCC
SCL
SDA
GND

3 to 5 Vdc
Serial clock line
Serial data line.
0 V

G0
G

0 V
10 to 30 Vdc / 12 to 28 Vac

WARNING: Device wiring and commissioning can only be carried out by qualified professionals. Always make the device wirings in de-energised electricity network.

WARNING: This product is appliance class III product according to IEC 60664-1. The product may only be connected to SELV (safety extra low voltage) electricity network.

CAUTION: The product may only be connected to overvoltage category I, II or III electricity network according to IEC 60664-1.

CAUTION: There is a risk of explosion if the battery is replaced by an incorrect type. Use only battery types that are defined by Greystone. Contact Greystone sales to get more information about recommended batteries.

CAUTION: Dispose the used batteries according to the instructions of local authorities.

ORDERING

PRODUCT	GWTRIM	Wireless Input Module, White
	GWTRBIM	Wireless Input Module, Black

PART NUMBER

GWTRIM
GWTRBIM

NOTE: Greystone Energy Systems, Inc. reserves the right to make design modifications without prior notice.



APPROVALS, SUPPORTED STANDARDS AND DIRECTIVES

<p>FCC/ISED</p>	<p>This device contains licence-exempt transmitter(s)/receiver(s) that comply with Innovation, Science and Economic Development Canada’s license exempt RSS(s) and complies with part 15 of the FCC Rules. Operation is subject to the following two conditions:</p> <ol style="list-style-type: none"> 1. This device may not cause harmful interference. 2. This device must accept any interference received, including interference that may cause undesired operation of the device. <p>L’émetteur/récepteur exempt de licence contenu dans le présent appareil est conforme aux CNR d’Innovation, Sciences et Développement économique Canada applicables aux appareils radio exempts de licence. L’exploitation est autorisée aux deux conditions suivantes :</p> <ol style="list-style-type: none"> 1. L’appareil ne doit pas produire de brouillage. 2. L’appareil doit accepter tout brouillage radioélectrique subi, même si le brouillage est susceptible d’en compromettre le fonctionnement. <p>Contains: FCC ID: XPYNINAB1 IC: 8595A-NINAB1</p>
<p>Responsible Party</p>	<p>Dent Instruments 925 SW Emkay Drive Bend, OR 97702 USA 1-541-388-4774</p>

STANDARD	DESCRIPTION
<p>2014/30/EU 2014/53/EU 2000/299/EC</p>	<p>Electromagnetic Compatibility (EMC). Radio Equipment Directive (RED). Classification of radio equipment: Class 1, Wideband data transmission systems (Subclass 22).</p>
<p>2011/65/EU (EU) 2015/863 EN IEC 62368-1:2020</p>	<p>Restriction of Hazardous Substances (RoHS2) Directive. Commission Delegated Directive, amending Annex II to Directive 2011/65/EU. Audio/video, information and communication technology equipment - Part 1: Safety requirements</p>
<p>EN 300 328 V2.2.2</p>	<p>Wideband transmission systems; Data transmission equipment operating in the 2,4 GHz ISM band and using wide band modulation techniques; Harmonised Standard covering the essential requirements of article 3.2 of directive 2014/53/EU.</p>
<p>EN 301 489-1 V2.2.3</p>	<p>Electromagnetic Compatibility (EMC) standard for radio equipment and services; Part 1: Common technical requirements.</p>
<p>EN 301 489-17 V2.2.1</p>	<p>Electromagnetic Compatibility (EMC) standard for radio equipment and services; Part 17: Specific conditions for Broadband Data Transmission systems.</p>
<p>SFS-EN IEC 63044-3:2018</p>	<p>Home and building electronic systems (HBES) and building automation and control systems (BACS) - Part 3: Electrical safety requirements</p>
<p>SFS-EN IEC 63044-5-1:2019</p>	<p>Home and building electronic systems (HBES) and building automation and control systems (BACS) - Part 5-1: EMC requirements, conditions and test set-up.</p>
<p>SFS-EN IEC 63044-5-2:2019</p>	<p>Home and building electronic systems (HBES) and building automation and control systems (BACS) - Part 5-2: EMC requirements for HBES/BACS used in residential, commercial and light-industrial environments.</p>
<p>SFS-EN IEC 63044-5-3:2019</p>	<p>Home and building electronic systems (HBES) and building automation and control systems (BACS) - Part 5-3: EMC requirements for HBES/BACS used in industrial environments.</p>

Changes or modifications made to this equipment not expressly approved by **Greystone** may void the FCC authorization to operate this equipment.

Note: This equipment has been tested and found to comply with the limits for a Class B digital device, pursuant to part 15 of the FCC Rules. These limits are designed to provide reasonable protection against harmful interference in a residential installation. This equipment generates, uses and can radiate radio frequency energy and, if not installed and used in accordance with the instructions, may cause harmful interference to radio communications. However, there is no guarantee that interference will not occur in a particular installation. If this equipment does cause harmful interference to radio or television reception, which can be determined by turning the equipment off and on, the user is encouraged to try to correct the interference by one or more of the following measures:

- Reorient or relocate the receiving antenna.
- Increase the separation between the equipment and receiver.
- Connect the equipment into an outlet on a circuit different from that to which the receiver is connected.
- Consult the dealer or an experienced radio/TV technician for help.

The radiated output power of the device is far below the 47 CFR 1.1310 radio frequency exposure limits. Nevertheless, the device should be used in such a manner that the potential for human contact during normal operation is minimized.

RADIOFREQUENCY RADIATION EXPOSURE INFORMATION

This equipment complies with radiation exposure limits set forth for an uncontrolled environment. This equipment should be installed and operated with minimum distance of 20 cm between the radiator and your body. This transmitter must not be co-located or operating in conjunction with any other antenna or transmitter.

Cet équipement est conforme aux limites d'exposition aux rayonnements ISED établies pour un environnement non contrôlé. Cet équipement doit être installé et utilisé avec un minimum de 20 cm de distance entre la source de rayonnement et votre corps. Ce transmetteur ne doit pas être placé au même endroit ou utilisé simultanément avec un autre transmetteur ou antenne.