

GREENHOUSE/HORTICULTURE SENSOR

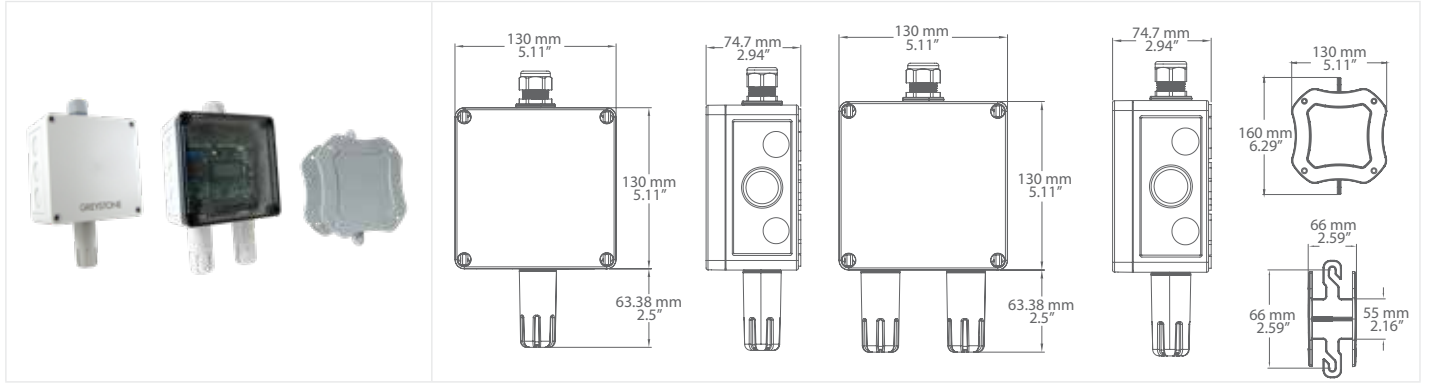

GH SERIES

GH2

GH3

PRODUCT DESCRIPTION

The GH Series Greenhouse/Horticulture sensor is designed for a greenhouse or indoor grow facility to monitor and allow control for optimum plant growing conditions. The GH Series is available in 2 models; Temperature & Humidity or Temperature, Humidity & Carbon Dioxide. The GH Series utilizes a highly accurate and reliable dual-channel, non-dispersive infrared (NDIR) sensor to monitor CO₂, a precision thermistor to monitor temperature and a thermoset polymer based capacitance sensor to measure humidity levels. All sensors are encapsulated in filtered sensor pods that are field replaceable. Features include an LCD for configuration and visual indication, various output signal types, and optional relays for alarm indication. An IP65 rated enclosure that can be either wall mounted or suspended from the ceiling is provided to protect against moisture penetration.

TYPICAL INSTALLATION

For complete installation and wiring details, please refer to the product installation instructions.

The horticulture sensor can be mounted directly onto any wall or flat surface, or may be suspended from the ceiling using the device cable harness which is secured to the enclosure with a compression style fitting.

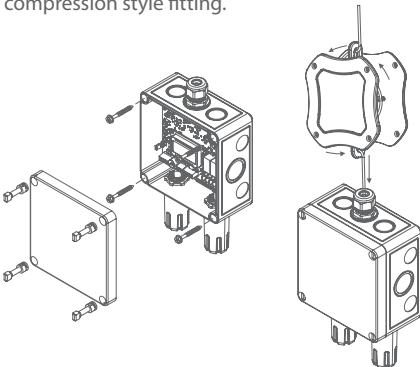

SPECIFICATIONS

POWER SUPPLY	24 Vac/dc ±20% (non-isolated half-wave rectified)
CONSUMPTION	Current: 120 mA max @ 24 Vdc, 220 mA max @ 24 Vac Voltage: 80 mA max @ 24 Vdc, 130 mA max @ 24 Vac BACnet®/Modbus: 75 mA max @ 24 Vdc, 125 mA max @ 24 Vac
PROTECTION CIRCUITRY	Reverse voltage protected and overvoltage protected
OPERATING CONDITIONS	-10 to 50°C (14 to 122°F), 5 to 95 %RH non-condensing
STORAGE CONDITIONS	-30 to 60°C (-22 to 140°F)
ENCLOSURE	IP65 (NEMA 4X)
ENCLOSURE DIMENSIONS	130mm W x 130mm H x 75mm D (5.12" x 5.12" x 2.95")
WIRING CONNECTIONS	Screw terminal block (14 to 22 AWG)
COUNTRY OF ORIGIN	Canada
LCD DISPLAY	Size: 35mm W x 15mm H (1.4" x 0.6") alpha-numeric 2 line x 8 characters Backlight: Enable or disable via menu or network
ANALOG OUTPUTS	Output Signals: 4-20 mA active (sourcing) or 0-5 Vdc / 0-10 Vdc Output Drive Capability: Current - 550Ω maximum Voltage - 5K Ω minimum
BACnet®	Interface: MS/TP, 2 wire RS-485 Baud Rate: 9600, 19200, 38400, 57600, 76800, or 115200 Address Range: 0 to 127
MODBUS	Interface: RTU, 2 wire RS-485 Baud Rate: 9600, 19200, 38400, 57600, 76800, or 115200 Address Range: 1 to 255
TEMPERATURE SENSOR	Type: NTC thermistor Accuracy: ±0.2°C (±0.4°F) Range: 0 to 50°C (32 to 122°F)
RELATIVE HUMIDITY SENSOR	Type: Thermoset polymer based capacitive Accuracy: ±2 %RH Range: 0 to 100 %RH Hysteresis: ±1.5 %RH Response Time: 15 seconds typical Stability: ±1 %RH typical @ 50 %RH in 5 years
CO₂ (GH3 MODEL)	Measurement Type: Dual-channel, non-dispersive infrared (NDIR), diffusion sampling Measurement Range: 0 to 5000 ppm Standard Accuracy: ±50 ppm +3% of reading Pressure Dependence: <1% of reading / kPa Response Time: 2 minutes (T90) Sensor Life Span: >10 years
OPTIONAL RELAY OUTPUTS	Contact Ratings: Form C (NO + NC), 2A @ 140 Vac, 2A @ 30 Vdc Setpoints + Hysteresis: Programmable via menu or network Time Delay: Programmable via menu or network



ORDERING		
PRODUCT	GH	Greenhouse/Horticulture Sensor
SENSORS	2	Temperature & Humidity
	3	Temperature, Humidity, & Carbon Dioxide
MOUNTING	SM	Suspension Mount (includes cable winder)
	WM	Wall Mount
ENCLOSURE	B	5" x 5" with smoked, transparent cover
	C	5" x 5" with solid cover
OUTPUT	I	Analog, 4-20 mA (2x or 3x)
	V	Analog, 0-5 or 0-10 Vdc (2x or 3x)
	B	BACnet® communications
	M	Modbus communications
RELAY	XX	None
	R1	1 Relay
	R2	2 Relay

PART NUMBER
GH

NOTE: Greystone Energy Systems, Inc. reserves the right to make design modifications without prior notice.

ACCESSORIES	
GHP-RHT	Relative Humidity/Temperature Replacement Pod
GHP-CO2	Carbon Dioxide Replacement Pod
GHP-CAP	Pod Protective Cap
GHS-WINDER	Cable Winder (included with SM model)

PART NUMBER



BACnet® COMMUNICATION

BACnet® is a data communication protocol for building automation and control networks. The sensor communicates on a standard 2-wire RS-485 MS/TP network designed to run at speeds from 9600 to 115200 baud over twisted pair wiring.

BACnet® is a registered trademark of ASHRAE. ASHRAE does not endorse, approve or test products for compliance with ASHRAE standards. Compliance of BACnet® listed products to the requirements of ASHRAE Standard 135 is the responsibility of BACnet® International (BI). BTL is a registered trademark of BI.

BACnet is a registered trademark of ASHRAE. ASHRAE does not endorse, approve or test products for compliance with ASHRAE standards. Compliance of listed products to requirements of ASHRAE Standard 135 is the responsibility of the BACnet International. BTL is a registered trademark of the BACnet International.

MODBUS COMMUNICATION

Modbus is a network protocol for industrial manufacturing environments. The sensor communicates on a standard Modbus network using the RTU (Remote Terminal Unit) transmission mode. The hardware interface is RS-485.

