

GREYSTONE

ENERGY SYSTEMS INC

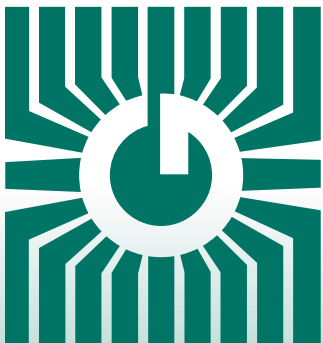

NITROGEN DIOXIDE DETECTOR NDD5B1100



Precision gas control/sensing

FEATURES:

- Superior electrochemical sensor
- 4-20 mA output
- Alarm relay with selectable trip level
- Easy to field calibrate
- Compact, IP65 (NEMA 4X) enclosure

*Peace of mind
through reliable
gas monitoring*

GREYSTONE HAS AN **ISO 9001** REGISTERED QUALITY SYSTEM

DESCRIPTION:

The NDD5B1100 nitrogen dioxide detector uses a superior electrochemical sensor for reliability and accuracy in the most critical applications. The NDD5B1100 provides a 3-wire sourcing 4-20 mA output as well as an alarm relay with three jumper selectable trip level settings.

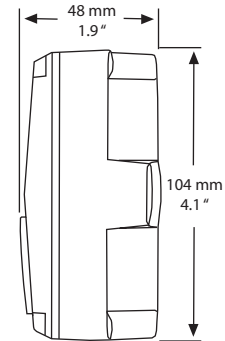
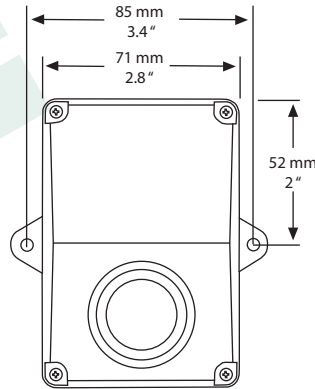

SPECIFICATION:

Sensor Type	Electrochemical
Sample Method	Diffusion
Measurement Range.....	0-10 PPM
Accuracy	±0.2 PPM or 5% of reading (whichever is greater)
Life Expectancy	>2 years
Typical Coverage Area	700 m ² (7500 ft ²) or 15 m (50 ft) radius
Operating Temperature	-20 - 50 °C (-4 - 122 °F)
Operating Humidity	15 - 90% RH (0 - 99% intermittent)
Pressure.....	Atmospheric ±10%
Power Supply.....	24 Vdc ±20% (non-isolated half-wave rectified) or 24 Vac ±10%
Consumption	50 mA max.
Output Signal.....	4-20 mA sourcing
Output Drive at Capability	550 ohms max. @ 24 Vac/Vdc
Relay Output	SPDT, Form C contact (N.O. and N.C.) 5 amps @ 30 Vdc, p.f. = 1 Trip Point: Low = 1, Mid = 3, High = 5 PPM, Hysteresis - 3%
Wiring Connections.....	Screw terminal block (14 to 22 AWG)
External Dimensions	71 x 104 x 48 mm (2.8" w x 4.1" h x 1.9" d)
Enclosure Ratings.....	ABS - UL94-5VB - IP65 (NEMA 4X)
Field Calibration.....	By applying calibration gas standards (Contact Greystone for calibration kit)

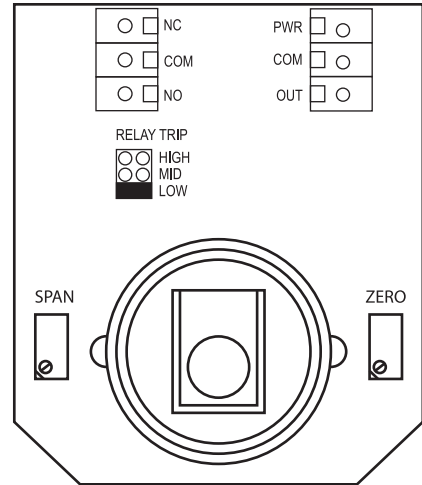

ORDERING INFO:

NDD5B1100



RoHS
COMPLIANT



Greystone Energy Systems Inc. is one of North America's largest ISO registered manufacturers of HVAC/R sensors and transmitters for Building Automation Management Systems.

We have conscientiously established a worldwide reputation as an industry leader by maintaining leading-edge design technology, prompt technical support, and a commitment to on-time deliveries. We take pride in our Quality Management System which is ISO 9001 certified, assuring our customers of consistent product reliability.

GREYSTONE HAS AN ISO 9001 REGISTERED QUALITY SYSTEM