

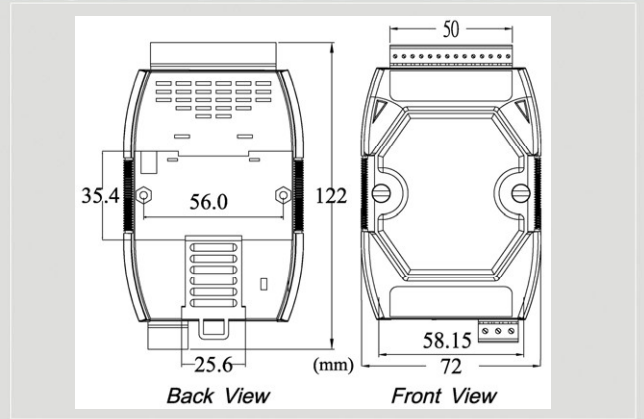

## Two-channel CAN Bus Isolated Bridge



I-7532



Dimensions

The I-7532 is a local CAN bridge used to establish a connection between two CAN bus system in a CAN network. The I-7532 stands by itself connecting adjacent wiring segments together as in the case of a CAN repeater (I-7531). Not just like I-7531, I-7532 have three more important features. First one, the transmission distance limitation of the CAN bus system on each side of I-7532 are independent, which means the total network distance can be extended. Second one, when the CAN bus system on one side of I-7532 happens some error (e.g. bit error), the system on other side can still work on correctly. Last one, the baud of two channels on I-7532 can be different for highly flexibility.

### Features

- Microprocessor inside with 72MHz
- 82C250 CAN transceiver
- 2500 V<sub>RMS</sub> photo coupler isolation on the CAN side
- 3KV galvanic isolation among the power supply and 2 CAN channels
- Support both CAN 2.0A and CAN 2.0B
- Fully compatible with the ISO 11898-2 standard
- Build-in jumper to select 120Ω terminal resistor
- Watchdog inside
- up to 100 CAN nodes on each channel
- Removable terminal block, Mounts easily on DIN-rail
- 768 frame buffer for each CAN channel

### Pin Assignments

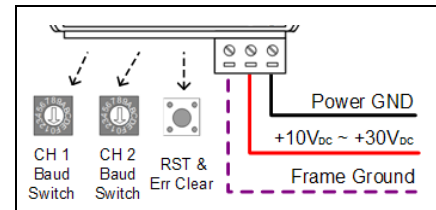
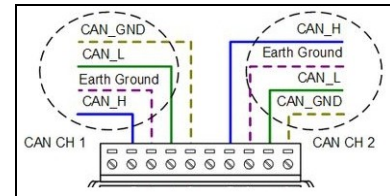

### Block Diagram

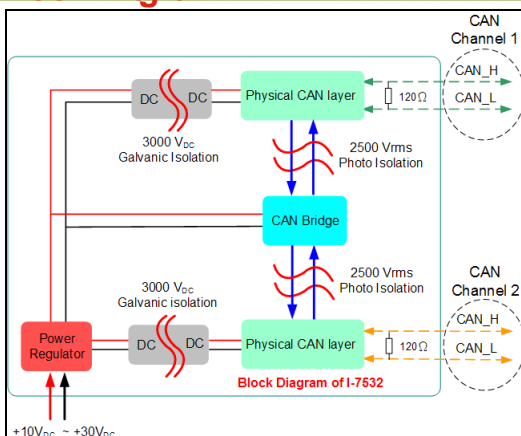

### Baud Rate Selection

Switch Value	0	1	2	3
Baud [bps]		5k	10k	20k
Switch Value	4	5	6	7
Baud [bps]	40k	50k	80k	100k
Switch Value	8	9	A	B
Baud [bps]	125k	200k	250k	400k
Switch Value	C	D	E	F
Baud [bps]	500k	600k	800k	1M



## Hardware Specifications

Item	I-7532
Micro Controller	Microprocessor inside with 72MHz
CAN Port Channels	2
CAN Transceiver	Philips 82C250
CAN Connector	10-pin removable screw terminal
Buad Rate selection by rotary switch	5K, 10K, 20K, 50K, 80K, 100K, 125K, 200K, 250K, 40K, 500K, 600K, 800K and 1Mbps
Isolation	2500 V <sub>RMS</sub> photo couple isolation between 2 CAN channel 3000 V <sub>DC</sub> galvanic isolation among the power supply and 2 CAN channel
Terminator Resistor	Selectable 120Ω terminator resistor by jumper
Support Protocol	CAN 2.0A/2.0B
<b>General</b>	
Power Requirement	Unregulated +10V <sub>C</sub> ~ +30 V <sub>DC</sub> Power reverse protection, Over-Voltage brown-out protection
Power Consumption	2W max
<b>Environment</b>	
Operating Temp.	-25°C to 75°C
Storage Temp.	-40°C to 80°C
Humidity	5~95% non-condensing
Dimensions	122mm x 72mm x 33mm (H x W x D)

## LED Indication



PWR LED	
ON	Power on
OFF	Power off

Rx LED	
Flashing	Transmission
OFF	Bus idle

ERR LED	
Flashing (100ms)	Transmission fail
Flashing (1sec)	Buffer overflow
ON	Bus off
OFF	No error

## RST & Err Clear Button

Reset & Error Clear button	
Click	Error clear
Push (3sec)	Module reset

## Application

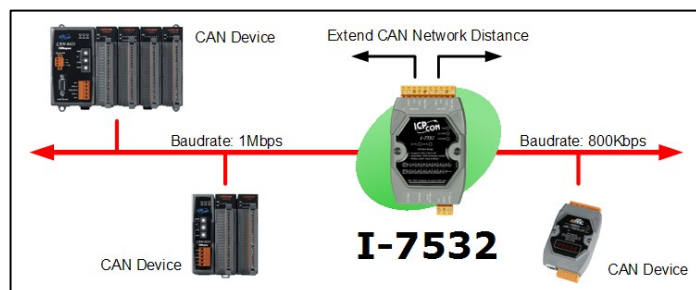

## Ordering Information

I-7532 CR	Two-channel CAN Bus Isolated Bridge (RoHS)
-----------	--